



NeoRhythm
By OmniPEMF



Neurostimulation Headband for Better Living

De-stress. Enhance your mental capacity.
Sleep & meditate better. Energize your body.
May help you living well with your pain.

SCIENTIFICALLY TESTED & PROVEN EFFECTIVE

*by two double-blind, placebo-controlled studies for Enhance Mental Capacity and Deep Relaxation programs.

1. Introduction

In a world full of options, we want to take a moment to say thank you for choosing us. Neurostimulation wearables are an excellent tool for achieving the desired state of body and mind. Please take your time to read this user manual carefully, even if you are familiar with a similar product. To ensure your safety and that of others, please read this user manual before using NeoRhythm. Please do not disassemble the device. It can be unsafe and will void the manufacturer's warranty.

2. Contents

1	Introduction	12	Customization of NeoRhythm's Headband
2	Device Description	13	Headband Positions
3	Included in the Package	14	Test Tube - How to Use and What Does It Tell You
4	Who Can and Can't Use NeoRhythm?	15	How to Use NeoRhythm Most Effectively
5	Age Restrictions	16	Maintenance and Cleaning
6	Possible Side Effects and General Precautions	17	Troubleshooting Guide
7	NeoRhythm Set-Up	18	Technical and System Specifications
8	How to Pair NeoRhythm with Your Mobile Device	19	Classification
9	NeoRhythm's Bluetooth® Settings	20	Safety Warnings
10	Controls	21	Manufacturer and Warranty Service
11	Light Indicators	22	Disclaimer

This appliance can be used by children older than 8 and persons with reduced physical, sensory or mental capabilities or lack of experience and knowledge if they have been given supervision or instructions concerning the use of the appliance in a safe manner and in addition to that understand the hazards involved. Children shall not play with the appliance. Children shall not clean or make any device maintenance without supervision.

This appliance contains non-replaceable batteries.

Must only be supplied with a safety extra-low voltage corresponding to the marking on the appliance.

The appliance is only to be used with the power supply unit provided with the appliance.

WARNING: To recharge the battery, use only the detachable supply unit provided with this appliance.

2. Device Description

NeoRhythm is the first brainwave entrainment device with a multi-coil structure and gesture controls, which makes it one of the most user-friendly neurostimulation devices on the market. It helps you get into the desired state of mind by emitting scientifically supported frequencies through electromagnetic fields. The brain synchronizes with these frequencies to help you relax, enhance focus, energize body and mind, fall asleep quicker and sleep better, meditate better, or help living well with your pain. With appropriate positioning of the coils inside the device which generate electromagnetic fields, we precisely target the right brain locations to get the desired effect. NeoRhythm's efficiency is confirmed by two independent double-blind, placebo-controlled studies and supported by many other scientific studies. To find out more, please visit <https://www.omnipemf.com/science-behind/>.

3. Included in the Package

1. NeoRhythm
2. Charging dock
3. Micro USB cable
4. Adjustment kit
5. User Manual
6. Test tube
7. NeoRhythm bag
8. Hard reset tool

4. Who CAN and CAN'T Use NeoRhythm?

CAN: NeoRhythm has been developed for the general public to safely and effectively induce many different brainwave states. The expected key benefit of using NeoRhythm is better living. When brainwave entrainment is regularly and properly applied, the expected results are improved sleep quality, a facilitated reach of specific awake states, as well as improved emotional and logical intelligence.

CAN'T: The use of a pulsed electromagnetic field device is contraindicated in people with **pacemakers** or other **electronic implants, non-MRI-safe IUDs, cochlear implants, or mechanical heart valves** because the magnetic field can shut the device off or otherwise interfere with its functioning. You also shouldn't use NeoRhythm if you have epilepsy, Graves' disease, or in the case of active bleeding.

Pulsed electromagnetic field is also contraindicated in **organ transplant patients** due to a possible risk of affecting the immune suppression/rejection process. There is a chance that electromagnetic fields may stimulate or activate a more aggressive rejection process by stimulating the immune system.

The safety of pulsed electromagnetic fields has not been established in **pregnancy**, although there is no evidence of harm. We advise against using NeoRhythm during pregnancy.

Patients should consult their doctors when thinking about using a pulse generator (NeoRhythm) with conventional medical treatment. This information is not a substitute for professional medical advice.

5. Age Restrictions

NeoRhythm should only be used by individuals aged 18 years or older (“Permitted Age”). If the user is of the Permitted Age but under the age of majority in the jurisdiction in which the user is domiciled, the user should review this manual and any applicable terms of use with their parent or guardian to make sure that the parent or guardian understands this manual and the applicable terms of use.

6. Possible Side Effects and General Precautions

NeoRhythm emits an electromagnetic field. There is no valid scientific reason to believe that NeoRhythm’s pulsed electromagnetic emission is harmful, but if you have concerns about exposure to these emissions, you should not use this device. Pulsed electromagnetic field side effects are usually non-existent or minor and temporary, but they may be observed in users who are hypersensitive to electromagnetic fields. It is very important to drink at least 8-10 oz (2-3 dl) of water before and after using NeoRhythm.

7. NeoRhythm Set-Up

1. Make sure your headband is fully charged.
2. Search your app store for NeoRhythm. Download the app.
3. Follow the in-app tutorial. It will guide you through connecting your headband to your mobile device and completing your first NeoRhythm session. How to connect both devices using Bluetooth® is also described in Chapter 8, How to Pair NeoRhythm with Your Mobile Device.
4. Join NeoRhythm’s social networks. They are a great place to learn more about the device and its features, share experience with other users, and chat with the team behind NeoRhythm.



8. How to Pair NeoRhythm with Your Mobile Device

NeoRhythm uses Bluetooth® to connect to your mobile device. The connection is managed through the NeoRhythm App.

How to pair?

1. Check if Bluetooth® is activated on your mobile device. Should you be using an Android phone, make sure GPS (location) is ON.
2. Tap NeoRhythm once to wake it up (confirmed by a green light - 1 blink per 5 sec).
3. Being on the home page of the app, click the button CONNECT. The app will recognize NeoRhythm and connect it to the phone in the background. When connected, the button will change from CONNECT to CONNECTED. If you have more than one NeoRhythms, a pop up with a device selection will appear, so chose one of the devices and the pairing will occur automatically. The led light on the headband will start blinking orange every second. Click NEXT. Here you can change the settings (light refers to whether or not the led light will be on, vibra – should the device vibrate or not when a program starts and ends, and stimulation status refers to whether or not NeoRhythm’s Bluetooth® will be ON or OFF). All three settings are ON by default. After managing the settings based on your needs, click SELECT PROGRAM. Chose the desired program from the list. Click on the desired stimulation duration and click SELECT.

When you finish using the headband, click on the home icon visible on the session page or every program’s page. That will lead you to the home page where by clicking Disconnect in the left corner, the connection with NeoRhythm will be ended.

By clicking NeoRhythm’s logo on each page you will be redirected to the home page.

If for unknown reasons, the Bluetooth® connection gets interrupted during a program is running, you will be redirected to the home page where you click CONNECT. The connection to the headband will be reestablished, and the program will continue.

9. NeoRhythm’s Bluetooth® Settings (Stimulation status in the app)

When NeoRhythm is activated, its Bluetooth® is automatically enabled and ready to connect with your device. However, the settings in the NeoRhythm App allow you to keep NeoRhythm’s Bluetooth® active while the stimulation process is on or to deactivate it WHILE the program is running, completely.

Bluetooth® during stimulation ON

This setting leaves Bluetooth® active also when you are using your NeoRhythm (a stimulation program is running).

ADVANTAGES:

- A countdown timer progress bar will be activated while the stimulation program is running.
- You will have access to the in-app statistics on your mobile device (duration of stimulation program used, frequency of past usage, etc.) once the program ends and the Bluetooth® connection is reestablished (automatically).
- It’s easier to change stimulation programs, as your phone doesn’t need to reestablish its Bluetooth® connection to NeoRhythm. Simply select a new program and tap NeoRhythm twice to start.

DISADVANTAGES:

- If Bluetooth® is also active during stimulation, it emits its own (much higher) frequencies.
- Your mobile phone has to be within the Bluetooth® connectivity range of the headband, or else due to connectivity loss, the data will not be synced.

Bluetooth® during stimulation OFF

This setting automatically deactivates NeoRhythm's Bluetooth® when a stimulation program starts and activates it again when the program ends. Bluetooth® is completely disabled ONLY while the program is running.

ADVANTAGES:

- No unwanted additional frequencies emitted during stimulation, just the ones NeoRhythm emits to help you reach the desired state of mind.
- You don't need your mobile device (only for setting up the program).

DISADVANTAGES:

- A countdown timer progress bar will not be activated while the stimulation program is running as the communication via Bluetooth® is not established.
- You will have access to the in-app statistics on your mobile device (duration of stimulation program used, frequency of past usage, etc.) only when you reconnect to the app via Bluetooth®. In this case, only the last 10 sessions run will be synced.
- Your mobile device needs to re-establish the connection to NeoRhythm every time you want to change the stimulation program. That means you will have to go to the home page and click CONNECT.
- Your mobile device won't be able to communicate with NeoRhythm during the stimulation. Visiting the homepage, you will see the CONNECT button active (can be clicked); however, the connection will not be established because the program is running, and NeoRhythm's Bluetooth® is OFF. You will have to stop (interrupt) the stimulation program with a double-tap and reconnect to your mobile device on the home page.

Which setting is better for you?

The ON option is selected by default, and we suggest that you leave it this way for the first few uses as it doesn't require to re-establish the connection each time you want to select a new stimulation program. You can turn it off later if you don't want the Bluetooth® to be active when you use your NeoRhythm.

NOTE: If you are using the same stimulation program most of the time, it is recommended that you turn Bluetooth® off in the app's settings. This will allow you to use your NeoRhythm only with the gesture controls – simply tap it twice (after waking it up) to restart your most recently used program.

How will I know that my chosen stimulation program has started/stopped if I turn off Bluetooth®?

Although you won't be able to see the progress bar, NeoRhythm will notify you when your chosen program starts/stops with vibrations and light indicators.

10. Controls

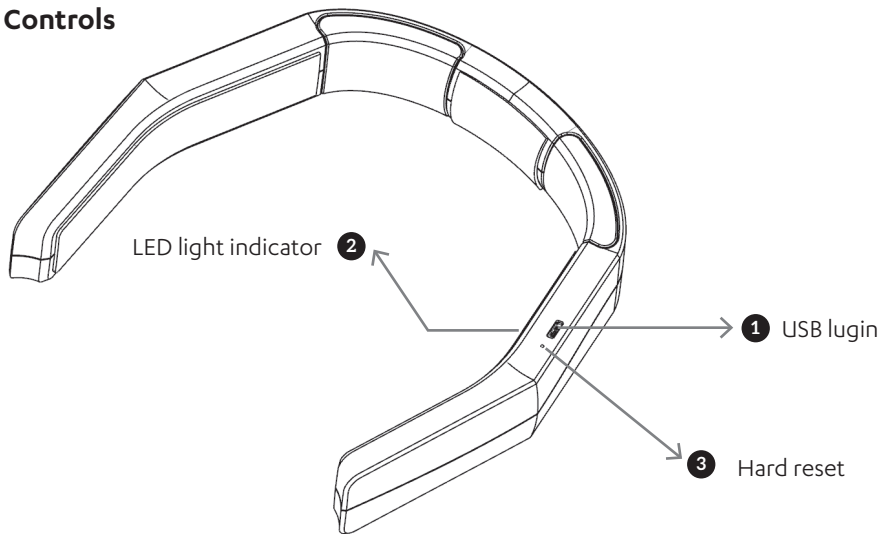

NeoRhythm is gesture-controlled. No buttons. No cables. Bluetooth® is also not required, except for when you are changing or choosing a new program. This makes NeoRhythm one of the most user-friendly devices on the market.

It is controlled by “taps,” so for regular use of the same program, you don’t even need your smartphone. A smartphone is only used for switching among different stimulation programs or changing the settings.

10.1. USING NEORHYTHM FOR THE FIRST TIME

For the first use, you need to charge your NeoRhythm via the micro USB port on the headband (number 1). The device will be fully charged in approximately 2.5 hours. Open the application, accept the terms of use, and click Easy login. That click will lead you to the 5 usage guides windows, so after a read click NEXT, and on the last window, click Finish Guide. Now you are on the home page of the app, so click the button CONNECT. The app will recognize NeoRhythm and connect it to the phone in the background. When connected, the button will change from CONNECT to CONNECTED. If you have more than one NeoRhythms, a pop up with a device selection will appear, so chose one of the devices and the pairing will occur automatically. The led light on the headband will start blinking orange every second. Click NEXT. Here you can change the settings (light refers to whether or not the led light will be on, vibra – should the device vibrate or no when a program starts and ends and stimulation status referring to whether or not NeoRhythm’s Bluetooth® will be ON or OFF). All three settings are ON by default, and can, later on, be manipulated by clicking Settings in the menu (make sure you are connected to the device to be able to change the settings). After managing the settings based on your needs, click SELECT PROGRAM. Chose the desired program from the list. Click on the desired stimulation duration and click SELECT. All you need to do now is to double-tap NeoRhythm right next to the led light, and your chosen program will start (confirmed by 1 short vibration). Tapping NeoRhythm twice is like pressing a start/stop button. The start of the program is confirmed by one short vibration, the interruption or end of the program is confirmed by two

short vibrations. Follow the LED light indicator (number 2) to check the status of the device. Blinking green 1 blink per second means that the program is running.

10.2. RESTARTING THE MOST RECENTLY USED PROGRAM

For example, if the last time you used your NeoRhythm was to fall asleep yesterday, the device is still set on the 'Improve Sleep' program. If you want to use it again this evening to help you fall asleep, you don't need your smartphone to start it. To start the last used program, first, gently tap the device once to wake it up (we suggest close to the light indicator or micro USB port), and then simply tap it twice. The start of the program is confirmed by 1 short vibration. Follow the LED light indicator (number 2) to check the status of the device. A blinking green light once per second means the program is running.

Note: NeoRhythm does not require the use of your smartphone while the program is running.

10.3. USING A DIFFERENT PROGRAM

If you want to start a different program from the most recently used one and NeoRhythm is turned off, first tap it once close to the led light indicator or the Micro USB port (to wake it up). Make sure the Bluetooth® connection is established (orange light blinking every second). Click Session, select the new program, desired time of use, and press the "SELECT" button in the app. Tap NeoRhythm twice and the new program will start (confirmed by 1 short vibration). Follow the LED light indicator (number 2) to check the status of the device. Blinking green light (1 blink per second) means the program is running.

If a program is currently running and you want to start using another program, first tap NeoRhythm twice to stop the current program (confirmed by 2 short vibrations), click on Session, select the new program, desired time of use, and press the "SELECT" button in the app. Tap NeoRhythm twice again, and the new program will start (confirmed by 1 short vibration). Follow the LED light indicator (number 2) to check the status of the device. A blinking green light once per second means the program is running.

10.4. STOPPING THE RUNNING PROGRAM

If you want to stop a running program to select and initialize another one, double-tap the device to interrupt the program already running; the headband will vibrate twice, meaning the program has stopped. Then choose the desired program and double-tap it again. If you want to stop a running program and stop using the device, all you need to do is tap NeoRhythm twice (confirmed by 2 short vibrations), and leave it. NeoRhythm will turn off by itself.

10.5. USING THE HARD RESET TOOL

If you encounter a problem and NeoRhythm stops functioning, you can use the hard reset feature (number 3).

When should you use hard reset?

- No response when charging the device,
- Wrong LED light color when charging/done charging/starting a new program (check the light signals described in the next chapter),

Always check if the battery is full. When resetting the device, insert the hard reset tool into the hole close to the micro USB port and push gently.

To keep you updated on the current state of the device, NeoRhythm has integrated 3 different color light indicators - orange, red, and green LED lights. Read more about them in the next chapter.

10.6. USING THE “LOCK NEORHYTHM” FUNCTION IN THE APP

If you want to turn NeoRhythm off completely, connect to the device via Bluetooth®, go under settings, and click LOCK NEORHYTHM. This will completely shut it down and lock it to prevent further use. To start using it again, plug it into a USB port to unlock it. All the statistics will be stored on the phone.

When to use this function?

You can lock your NeoRhythm when traveling or carrying it in a bag/purse/backpack for more extended periods to prevent unintentional use.

11. Light Indicators

The LED lights on the left side of the flat surface of the device indicate the working state of NeoRhythm. NeoRhythm has integrated orange, red, and green lights.

1. Blinking red light: The battery is low and you have to recharge the device.
2. Blinking orange light (1 blink per second): NeoRhythm is connected to your phone via Bluetooth®.
3. Orange light on: NeoRhythm is charging, USB is plugged in.
4. No light on when charging: NeoRhythm is fully charged.
5. Blinking green light (1 blink per second): The chosen stimulation program is running.
6. Slowly blinking green light (1 blink per 5 seconds): NeoRhythm is on standby; USB is unplugged.

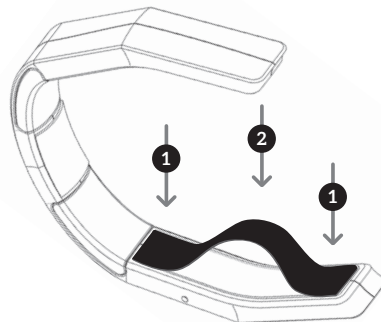

12. Customization of NeoRhythm’s Headband

NeoRhythm is designed to fit most heads. The headband should be suitable for at least 90% of people with different head sizes and shapes. Individual characteristics will sometimes require customization of the headband. In this case, you can use the included Adjustment kit to make sure NeoRhythm fits your head perfectly.

We advise you to first try NeoRhythm as it is. If it fits your head, no further action is required. If it feels loose and it feels like it’s going to slide off your head, use the included extra pads to make it fit comfortably.

The default side and front pads are 1.6 mm (0.063 in) thick. The Adjustment Kit includes extra pads that are 3 mm (0.118 in) and 6 mm (0.236 in) thick.

How to Select the Right Pads

Before sticking the self-adhesive surface of the pads onto NeoRhythm, we recommend that you just place the pads on the appropriate spot and try wearing the headband to find out which thickness of pads works best for you. After that, you can either remove the default pads and stick the chosen extra pads onto their place, or simply stick the chosen extra pads onto the default pads.

How to Stick the Extra Pads for a Perfect Fit

1. Remove the protective foil on the pad to expose its self-adhesive surface.
2. Align the edges of the pad with the edges of the corresponding area on the headband and stick just the edges first.
3. Press the middle of the pad down to the surface of the headband to stick the remainder of the pad. Failing to stick the edges first as described may result in pads not being aligned with the surface of the headband.

Failing to stick the edges first as described may result in pads not being aligned with the surface of the headband.

NeoRhythm Adjustment Kit includes:

- 6 x Big Pads (114 x 19,6 mm) in 3 different thicknesses (1.5 mm, 3 mm, 6 mm)
- 1 x Medium Pad (36.5 x 23.5 mm) in 1 thicknesses (3 mm)

Warning: Contains small parts that pose a choking hazard. Keep away from young children.

13. Headband Positions

NeoRhythm has five specially designed coils that generate electromagnetic fields and are powered by a pulse generator also located in the headband. The ability to adapt stimulation zones to the chosen program is a unique advantage of NeoRhythm - a benefit that enables it to target the right part of the brain more efficiently. That is why we wear NeoRhythm in different positions on the head depending on the chosen stimulation program.

Note: The positions shown below can be slightly adjusted to better fit your individual needs and make wearing NeoRhythm comfortable in any situation. Changing the headband's position for up to about an inch (3-4 cm) won't decrease its effectiveness or interfere with its functioning in any significant way.

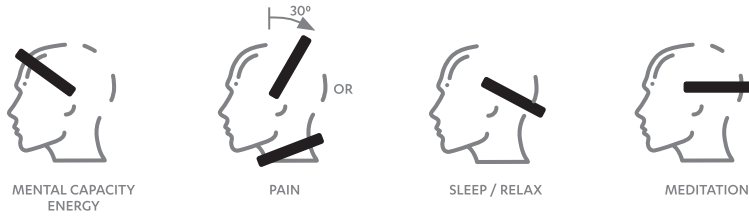

Note: Proper headband positioning is also shown within each stimulation program in the NeoRhythm App.

14. Test Tube - How to Use and What Does It Tell You?

In most cases, the non-invasive pulses are not tangible. Because of that reason, we added a magnetic tester tube in the NeoRhythm package with which you can hear the impulses emitted by the headband. It can be used to confirm that a stimulation program is running (NeoRhythm emits an electromagnetic field when active and the magnet reacts to it - you can hear a sound when listening to the test tube).

You can also test the frequency of pulsed electromagnetic fields in different stimulation programs, as well as observe the change in the strength of the electromagnetic field as the test tube moves away from or closer to NeoRhythm.

What do you actually hear when using the tube?

As the magnet in the tube reacts to the magnetic field produced, you get to hear the frequency of the electromagnetic pulses emitted by the coils inside NeoRhythm.

Testing the FREQUENCY of different stimulation programs

Choose the desired program in the application, run it and place the test tube on NeoRhythm. The test tube must touch the device. Place the glassy bottom of the tube on the device and place your ear on the other side where the silver cap is. Testing is done on both the ends of the headband and in the middle of it. That is where the coils are placed and the impulses can be heard. If you, for example, choose the Improve Sleep program, you will be able to hear a low frequency, because this program uses low frequencies of theta brainwaves to calm your brain and prepare it for sleep. It will sound like a slow beating (with 3-4 beats per second). Then try the Enhance Mental Capacity program. Select it in the application, run it, and move the test tube close to NeoRhythm. The sound frequency will be much higher because the Enhance Mental Capacity program uses beta brainwave frequencies to sharpen your brain and prepare it for intensely focused work. This program produces a fast-beating noise (with 30+ beats per second).

Testing the STRENGTH of the electromagnetic field

Turn on the device. Move the test tube close to NeoRhythm and listen carefully. The magnet in the test tube will produce a sound. The sound will be more intense and louder when the test tube is closer to NeoRhythm. If you increase the distance, the sound will slowly fade away. This happens because the intensity of the magnetic field decreases with distance from the surface of the headband.

15. How to Use NeoRhythm Most Effectively

Recommendations

1. For general wellness, it is recommended that you use your NeoRhythm twice a day. That helps recharge your cells to oBluetooth®ain their optimal state. Check the in-app instructions found inside each stimulation program to learn what is the recommended usage frequency and the duration of stimulation.
2. It is recommended to drink enough water (at least 8-10 8-ounce cups or 2 liters a day) and at least one 8-ounce (2 dl) cup of water before using NeoRhythm and immediately after as to help facilitate the natural release of toxins.
3. Eat a healthy diet, free of chemicals and pesticides, refined foods and sugar, and consume a lot of green vegetables.

16. Maintenance and Cleaning

Do not use NeoRhythm near water and when you are wet. NeoRhythm is not water-resistant but may be wiped down with a damp cloth for cleaning.

Avoid excessive physical impact to the device, and do not stretch or bend it as this can damage the PEMF coils and the hardware. The manufacturer does not take responsibility for devices damaged by improper use.

17. Troubleshooting Guide

Remember: The device is very simple to use and only a few things can go wrong.

It is important to know that we are always here for you. If you have any questions, please contact us through our social media (FB) or by email (foryou@omnipemf.com) also found on our website.

The LED indicator is not working.

Recharge the battery. Check the USB cable.

The device has been exposed to excessive amounts of water.

NeoRhythm is not designed to be waterproof, although short exposure to water may not permanently damage the device. If NeoRhythm has been exposed to water, recovery may be possible by placing the unit in a sealed bag or a container with dry uncooked rice for 2 to 3 days. The rice will act as a desiccant and slowly remove the moisture.

NeoRhythm fails to help the problem for which it was purchased.

First, verify that NeoRhythm is functioning. Make sure that the battery is fully functional for the whole duration of stimulation each time it is used. Make sure the LED lights are functioning and that the green light is blinking. Make sure that the start of the program is confirmed by 1 short vibration.

Contact us through our social media (FB) accounts or by email about using NeoRhythm. It is possible that the headband has been placed incorrectly. There are four different positions for using NeoRhythm. In many cases, simply adjusting the headband placement greatly improves the effectiveness of the device.

It is also possible that the period of use has not been long enough for the desired effect to be seen. Consider using NeoRhythm regularly for 2 to 3 weeks. Beneficial effects are usually seen within the first few days.

NeoRhythm seems to help, but then the problem eventually comes back.

If a short period of using NeoRhythm yielded good results, but then after not using NeoRhythm for a while, the problem

recurs, consider using NeoRhythm for a more extended period. Proper nutritional support and supplements are also helpful in conjunction with using NeoRhythm.

18. Technical and System Specification

Operating system	Android 5.1 and above iOS 7 and above
Waveform	Trapezoidal
Frequency Range	3 - 303.41 Hz
Maximum Magnetic Field Intensity	25 gauss (2.5 mT)
Number of Programs	7
Program Duration	30 min - 8 hours; selected minutes or continuous
Power	Internal rechargeable battery
Weight	105 g
Dimensions	160 mm (6.3 in) x 170 mm (6.7 in) x 28 mm (1.1 in)
Warranty	2 years

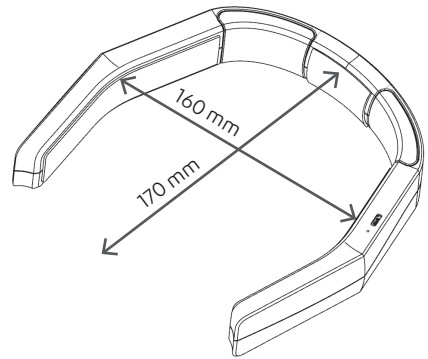

19. Classification

NeoRhythm is classified as a household device.

CE regulatory information:

- Safety: EN 60335-1
- EMC EN 303 4461 (EN 55014-1/2)
- Radio Equipment Directive (RED) 2014/53/EU

FCC regulatory information:

- device complies with part 15 of the FCC Rules



We are proud to use recyclable materials for our packaging to help protect the environment.

20. Safety Warnings

- Do not expose NeoRhythm to fire, place it near a hot oven, or mechanically crush or cut the device or its battery, as this may result in an explosion.
- Do not expose NeoRhythm to extremely high temperatures, as this may result in an explosion or leakage of flammable liquid or gas.
- Do not expose NeoRhythm to extremely low air pressure, as this may result in an explosion or leakage of flammable liquid or gas.
- Don't attempt to replace NeoRhythm's battery yourself – you may damage the battery, which could cause overheating and/or injuries.

21. **Manufacturer and Warranty Service**

MANUFACTURER

MDCN TECH Ltd

Made in Europe

WARRANTY SERVICE

US distributor: MDCN TECHNOLOGIES INC.

Contact

Email: foryou@omnipemf.com

There is a two-year warranty on all OMNIPEMF devices that starts the day of the purchase. However, it is not valid in the following cases:

- Failure or damage due to improper usage
- Damage and contamination of the device caused by improper protection
- If the device has been opened during the warranty period"

22. **DISCLAIMER**

MDCNTECHLTD and its distributors offer low risk, general wellness products that promote a healthy lifestyle, help to maintain or encourage good health, or reduce the impact or risk of some chronic diseases and conditions where a healthy lifestyle has been shown to play an essential role in improving quality of life and living well. These statements have not been evaluated by the FDA and products are not intended to diagnose, treat, cure, or prevent any disease or medical condition. PEMF products are meant to address energetic elements that aid the body's natural healing abilities and help restore and maintain energetic balance. The therapeutic low- and medium-intensity pulsed electromagnetic fields generated by these products use similar levels of energy as the natural vitalizing energy of the Earth. The use of a PEMF product is contraindicated in people with pacemakers or other electronic implants, cochlear implants, or mechanical heart valves. PEMF products are also contraindicated during pregnancy and in people with epilepsy or bleeding. PEMF therapy is also contraindicated for: organ transplant recipients or those on immunosuppressive therapy and those with non-MRI-safe IUDs. Patients should tell their physicians when they are thinking about using NeoRhythm⁺ with conventional medical treatment. This information is not a substitute for professional medical advice. If you have or suspect a medical problem, please consult your healthcare provider. Content generated or found through MDCN TECH LTD services or products is for informational purposes only, S and is not intended to replace the relationship between you and your physician or other healthcare providers. MDCN TECH LTD is not a licensed medical or health-care provider and has no expertise in diagnosing, examining, or treating medical conditions of any kind.



app store



google play



www.omnipemf.com